

WWW.NYLACAST.COM



Nylacast Limited

200 Hastings Road . Leicester . England LE5 0HL
Tel: + 44 116 2768558 . Fax:+ 44 116 2741954
Email: sales@nylacast.com



Nylacast LLC

770 Maple Street . Lebanon . PA17 046 USA
Tel: 001 717 2705600 . Fax: 001 717 2709760
Email: sales@nylacastusa.com



Nylacast South Africa (PTY)

PO Box 30445 . Jet Park . Johannesburg SA
Tel: 00 2711 3977077 . Fax: 00 2711 3977017
Email: nylacast@mweb.co.za

www.nylacast.com



ENGINEERING PLASTIC SOLUTIONS

PIONEERING NYLON SHEAVES



Committed to excellence

Nylacast has been at the forefront of design and application development of Sheaves for over 40 years. Utilising the latest in CAD/CAM technology and enhanced engineering excellence, Nylacast sheaves have been in demand for many decades now. This coupled with our expertise and knowledge in polymers materials makes Nylacast sheaves the ideal choice for your application. Industry users for Nylacast sheaves include those involved in Construction Equipment, Oil & Gas, Agriculture, Food Processing and Packaging and Quarrying and Mining to name a few.

Advantages of Nylacast Sheaves over Steel Sheaves

Using advanced polymers, in particular those based around cast nylon, allow for a number of significant advantages in sheave application. These include increased wire rope life, reduced component weight, protection against corrosion, reduced maintenance costs whilst offering improved lifting. In addition, Nylacast sheaves can be specifically formulated with modifiers and internal lubricant packages (Nylacast Oilon and Nylube) appropriate to end use which further enhances performance.



Case study

Launch and Recovery Sheave.

The versatile strength of Nylon Sheaves sees them used more today than ever in ROV Launch and Recovery Systems (LARS). In the LARS application the sheave wheel is fitted to the 'A' frame or crane of greater diameter than the minimum bend radius of the ROV umbilical. The key factor is the strength of the Nylon material that allows for the weight of the ROV system as well as any increase in weight due to heavy sea states.



Nylacast Sheaves:

- › 1" diameter to over 82"
- › Made to order
- › Provides Increased wire rope life
- › Reduced component weight
- › Protected against corrosion
- › Reduced maintenance cost
- › Improved lifting

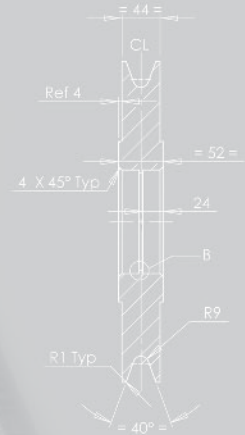
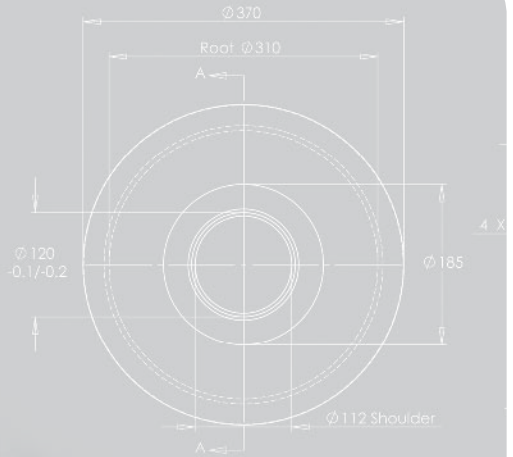

Industry users include

- › Construction Equipment
- › Crane Equipment
- › Oil and Gas
- › Maritime
- › LARS
- › Agriculture
- › Food Processing
- › Packaging
- › Defence
- › Quarrying and Mining

Contact us

For further information please contact one of our technical engineers on +44 (0) 116 276 8558 or alternatively visit www.nylacast.com